

# HitchHiker user Guide

## HitchHiker

Bring network awareness to  
non-networked equipment.



Inside -

- Quick start
- Configuration
- Connecting to the network and making links
- Serial, parallel and digital I/O ports
- Temperature and humidity measurement

Enhanced protocol support pack -

- ◆ SNMP support
- ◆ TFTP software upgrade
- ◆ Local processing of inputs and outputs
- ◆ IP broadcasting

Hardware options -

- ◆ The expansion relay I/O option
- ◆ -48VDC power supply option
- ◆ The remote controlled mains socket

For the latest User Guide, free downloads, technical support documents and more, please visit our web site – [www.mutek.co.uk](http://www.mutek.co.uk).

## Contents -

- Quick start - for the impatient.
- Pre-connect configuration - Entering IP addresses, unit name, password and Port names
- Connecting to the network - Who is connected?
- Making links between units
  - Source and destination units and ports. Notes on routers.
  - Broadcasting.
  - UDP socket to socket links
- Serial port and Parallel port configuration
- Setting packet send parameters.
- Contact sense inputs, Relay outputs - links between digital inputs and outputs.
- Embedded command strings.
- Changing the menu mode trigger character.
- The back panel connectors and DIP switch
  - Connector pin signal assignments for serial and parallel ports.
  - Option switch settings.
  - Restoring factory defaults.
  - Pin assignments and use of the digital I/O ports.
  - Temperature and humidity measurement.
- General comments - HitchHikers use of UDP, using bridges and routers; keep alive heartbeat; effect on Ethernet traffic.
- Specification.
- Addendum 1 - Enhanced protocol support pack. Optional feature.
  - SNMP support.
  - Local processing - Boolean logic equations.
  - TFTP Upgrade option.
  - IP broadcasting and IGMP.
- Hardware options -
  - The expansion relay I/O option.
  - -48Vdc power supply option.
  - The remote Controlled Mains socket
- Addendum 2 - HitchHiker packet protocol.
- Addendum 3 - Menu tree.

### Quick start - for the impatient.

1) Power up each unit and see the LEDs cycle through a startup pattern and finally stabilise after a few seconds, with the C/D led green (Centronics=green, DataProducts=red), and the power led on. Set the option DIP switches 1 and 2 for the network connection you require- see page 13.

2) Connect all the units (at least two) to a single network segment or hub.

3) Connect a terminal, set for 9600 baud, 8, N, 1 to HitchHiker port 2 (CMD port- 9 pin D nearest the mains connector). The serial ports are configured as DCEs, so a straight through cable is needed.

4) Type ++++ and see the HitchHiker root menu and the red 'Cmd' led. NB. your PC or terminal must assert RTS (D25 pin 4 = D9 pin 7) or HitchHiker cannot output. (If it cannot, then use HitchHiker pin 1 which presents +12v, and link it to RTS on pin 7.) This applies to both serial ports regardless of the selected handshake method, and applies to both command and data mode.

Note - after a few minutes UTP units will automatically drop out of menu mode if they are not connected to a hub.

5) Use the menu selection 'Display units on line' and ensure you have an entry for each connected unit; one local unit and one or more remote units listed below it. Notice that the firmware version number is displayed for all the units. It is best if they are all the same version- contact your distributor in case of query. Press SPACE or RETURN to return to the main menu.

6) Enter the 'Configure Unit' menu and enter the name 'HitchHiker' (upper or lower case is OK), and the password 'pass'. Enter 3 IP addresses - one for the unit, one for the default gateway, and the subnet mask. (you do not *have* to do this if all the units will be on one subnet). Enter IP numbers as dotted quads e.g. 158.152.46.132. Also rename the unit, otherwise you will have more than one unit with the same name, which is confusing! Save the changes.

- Connect to each unit and repeat steps 4, 5 and 6. Once you have given each unit its own name and optionally an IP number, you can configure it remotely.

7) Make a link between any pair of units that are connected to the same network segment. When prompted for Source and Destination unit names, enter the IP numbers (or names). Save the link. Exit command mode by pressing Escape. Try passing data across the logical link you have made.

A good first try is to link port 2 on the local unit to port 2 on another unit. Make two wire links on the chosen remote units serial port 2- D9 pin 2 to 3 (data loop back) and D9 pin 6 to 7 (+12v to RTS). You can then leave your PC/terminal connected to your local port 2, exit command mode (Esc), and type characters which should echo back onto your screen, having been looped back by the remote unit.

NB: If you decide to test the parallel ports, they default to output, like a PC parallel port. If you want to connect it to a printer that's fine. If you are going to connect a computer to it, change it to an input port first.

8) Whenever you are configuring or linking to units on remote subnets, you must use IP numbers, not names.

In case of problems, read the detailed sections of the manual which follow. Happy HitchHiking!

## Introduction

HitchHiker lets your serial and parallel data 'hitch hike' across a standard Ethernet network, allowing it to be used for general data transport tasks without interfering with normal network operations. HitchHiker is 802.3 compliant and uses protocols from the TCP/IP suite, making it fully routable.

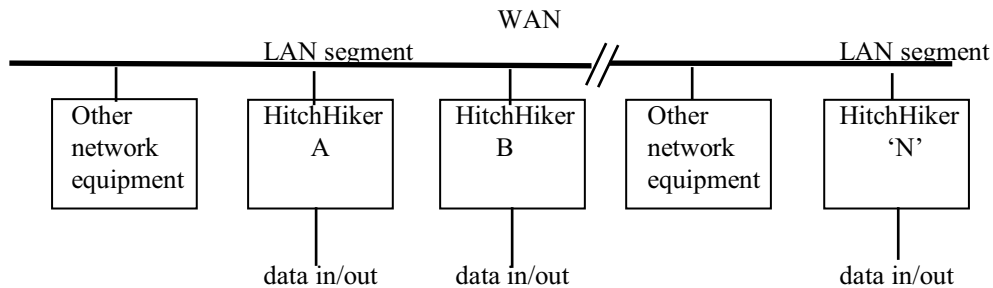

Each unit has two RS232C ports, a parallel port, a network port (choose from BNC, UTP or AUI) and optionally eight general purpose in/out signals and four temperature and humidity sense inputs. You may connect as many units as you wish to the network and establish logical connections between units with complete flexibility. For example, imagine two units each connected to any two points of the network. The three ports and the digital I/O pins can be set up as shown below so that they all carry data simultaneously -

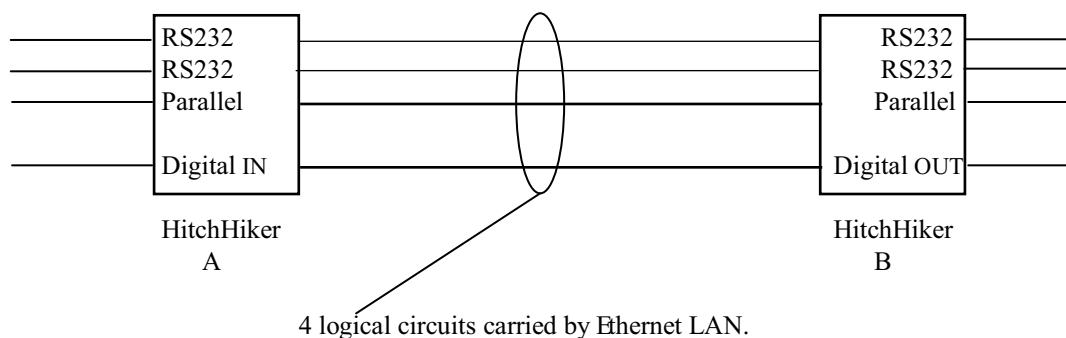

Although the above example shows the four ports linked in a one-to-one fashion to another unit, HitchHiker allows its ports to be individually linked to any port of any other unit. You can connect as many HitchHikers as you wish to your network, obeying normal Ethernet rules of course, and set up connections between units with complete freedom. For example, set one unit to accept data from several other units -

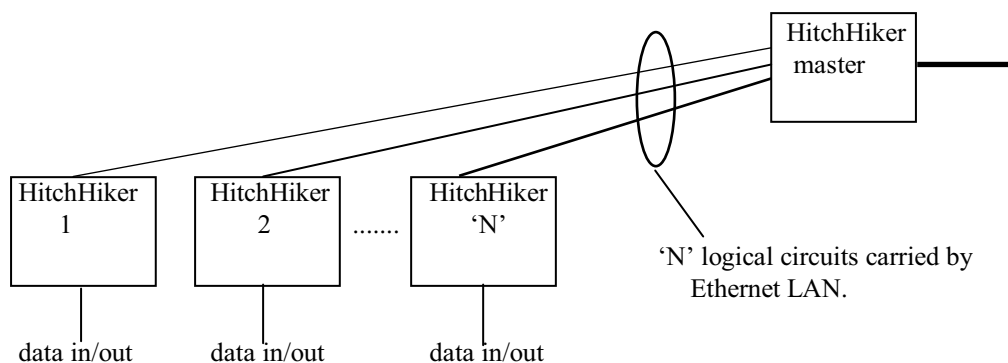

These and many other configurations can be easily set up, monitored and changed at will from any unit on the network. The HitchHiker command mode menu allows you to make and break logical links between units, examine and change configurations, unit names, IP numbers etc. of any HitchHiker on the network. Security is provided by a password for every unit.

HitchHiker provides error corrected, self repairing logical links. Every network packet is error checked and sequence numbered to ensure all your data is delivered and is error free. Should the network or the power fail, HitchHikers will *automatically* re-link when the problem is resolved.

#### Pre-connect configuration.

You must make a few minor configuration changes to each unit before you connect them to your network. The most important thing is to give each unit a unique name and IP number. If you do not do this you cannot make links from one unit to another! Each unit has storage for all user configurations and these configurations are reloaded each time the unit is powered up. Power up the unit and allow the initialisation sequence to run until only the ON and C/D LEDs remain lit.

HitchHiker is configured via serial port two, the D9 connector nearest the mains socket, which defaults to 9600 baud, 8,N,1. The serial ports are configured as DCE (internal links allow DTE selection) so a normal PC serial cable can be used without crossovers.

To enter the Command menu mode type ++++ to port 2, or press the concealed 'Mode' push button recessed just behind the front panel. Serial port two 'Cmd' led will light and the HitchHiker root menu will appear. A menu tree is included at the end of this manual. A new or cold started unit will ask you to enter its IP address, the IP address of the default gateway and the subnet mask now. Use numbers provided by your network manager. If all the units are going to be connected to the same LAN segment with no routers (gateways) to other networks, you can invent IP numbers. For example assign the default gateway the number 1.1.1.1, assign the units IP numbers in the range 1.1.1.2 to 1.1.1.255, and use a sub-net mask of 255.255.255.0. **NB:** If you are planning to PING units from your workstation, it must have an IP number consistent with your numbering scheme i.e. a number somewhere in the range 1.1.1.2 to 1.1.1.255 in the example above.

At this stage you may rename each unit to suit your site. You may also change passwords, port names, port settings. All these settings are changed using selections in the 'Configure Unit', menu

- At the prompt 'Enter name of unit to configure', enter the factory default 'HitchHiker'.
- Answer the prompt 'Enter password for unit', with the factory default 'pass' in upper or lower case. Characters are echoed as asterisks.
- Rename the unit, and if desired change the password.

If you wish to change the port names enter the 'Configure port' menus for each port. The factory default port names are; serial port 1 = 'port1'; serial port 2 = 'port2'; bidirectional parallel port (D25 female) = 'port3'.

Notes -

- To configure units on other sub-nets, enter its IP number when prompted for the unitname.
- Remember to *Save* your changes before escaping from command mode.

#### Connecting to the network.

Now you can connect your units to the network. On any unit enter Command mode and use the 'Display units on line' menu selection for a report of all the HitchHikers connected to the local LAN segment. You will not see units on other sub-nets. If you connect a printer to the parallel port, remember to set the port as an output port, you can use the 'Print list of units on line' menu selection to print the list of all connected units. These options are a good test of the unit's ability to communicate correctly on the network. You should see LEDs flash for outgoing and incoming network packets Note; HitchHiker responds to its own protocols and network Arp broadcasts.

### Making links.

You can now form links between units. A 'link' is a data route starting at a source port on one unit and ending at a destination port on any other unit. The source and destination ports may be of different type (serial or parallel) and the data formats (number of data bits etc.) may also be different. Even the digital I/O ports can be linked. The unit allocates buffer memory for the RS232 and the parallel ports.

Use the 'Set up link' menu selection' and see the prompt 'Enter name of Source Unit'. You may enter its name - the unit will search the local sub-net for a unit of the given name, and if it is found you will be prompted to enter its password. Alternatively you may enter its IP number. Next you will be asked to identify the source port number, 1, 2, 3 or 4 for digital I/O. You will now be prompted for the name of the Destination unit (or to enter 'none' or 'multi', more below). You may enter a name or IP number as before. You will be prompted to identify the destination port number on that unit - if you chose digital I/O (port4) on the source unit, port 4 is assumed on the destination unit. Lastly you will be prompted for a time-out. This time value is passed to the destination output port, which will not allow any other user to connect to that port until it has been empty and idle for the chosen time. Choose from 2 sec, 20 sec, 2 minutes or 'never'. Having made the link, remember to save it. Escape exits without saving the changes.

### Port to port links (V1.43i onwards)

It is possible to enter the same name or IP number as the source and destination unit. In this way it is possible to send data between the two serial ports, or even loop data back on a single port!

### Wide Area Networks.

If you connect units on different sub-nets of a WAN system you must refer to units by their IP numbers and you must define default gateways and sub-net masks for every unit. Your network administrator can provide this information. If you connect all units to one sub-net, IP numbers can be ignored or invented, see 'Pre connect configuration' for suggested IP numbering.

### Valid responses to the prompt for a 'unit name'-

Whenever you are prompted to enter a unit name you can enter either-

1. An IP number. This can be used to refer to units situated anywhere on the network.
2. The name of a HitchHiker connected to the local network. A multicast enquiry is sent to look for a unit of this name. It will not pass through routers to units situated on remote sub-nets.
3. The word 'none' - simply a way of clearing a previously set link.
4. The word 'multi' - used to set up Mac multicast from one unit to many units on the same sub-net.

### Data broadcast, or Mac Multicasting

Data broadcast may be selected as a link option on any input port by using the special word 'multi' (which stands for multicast) instead of the name of a destination unit. This option allows data to be broadcast to all other units on the same sub-net. Data arriving at the broadcasting source port is sent to all other HitchHikers connected to the local network (not units on other sub-nets), and output by them on the port you selected as the destination port.

For example, specify unit John, port 1 as the source unit/port. Enter 'multi' as the destination unit 'name'. Select a destination port, for example port 2, and all data arriving at unit John port 1 will be sent to port 2 of every other HitchHiker on the local network.

Notes -

- You must assign IP numbers and sub-net masks to all units.
- Broadcast data travels across the network as multicast packets, that is they have the broadcast bit set in the destination Mac address field.
- Multicast packets are not acknowledged by receiving units, making this data delivery method less secure than normal links.

### Reverse channel data when using data broadcast-

If a serial port (1 or 2) is selected as the destination broadcast port, equipment's connected to these ports can respond to the broadcast data and establish full duplex links back to the broadcast unit. In our previous example let's say that the HitchHikers receiving the broadcast data are connected to terminals displaying the broadcast data. If a terminal user typed a key, its HitchHiker would establish a full duplex link back to the broadcast unit and then send the keystroke back to it. If another terminal user typed, its HitchHiker may have to wait for the idle time out at the broadcast unit to elapse before it can send its data. So every unit can send back to the broadcasting unit, but each must wait for the broadcast unit's reverse channel idle time out to elapse.

### Notes -

- You must assign IP numbers and sub-net masks to all units.
- Clear broadcast links by typing the special word 'none' instead of a destination unit name.
- In the reverse channel link example above, each user typing data back, has exclusive use of the broadcasting unit until its idle time out elapses. Then any other unit can gain access.
- When the a reverse channel link is made in this way, data from the broadcasting unit is still in broadcast mode - so every other unit on the sub-net hears half of the full duplex conversation between the two.

### UDP socket to socket links. (V1.43 onwards)

HitchHiker can be configured to send and receive 'raw' UDP packets, that is the UDP data field does not contain the underlying rugged HitchHiker protocol. Use this type of configuration to send data to a host CPU -

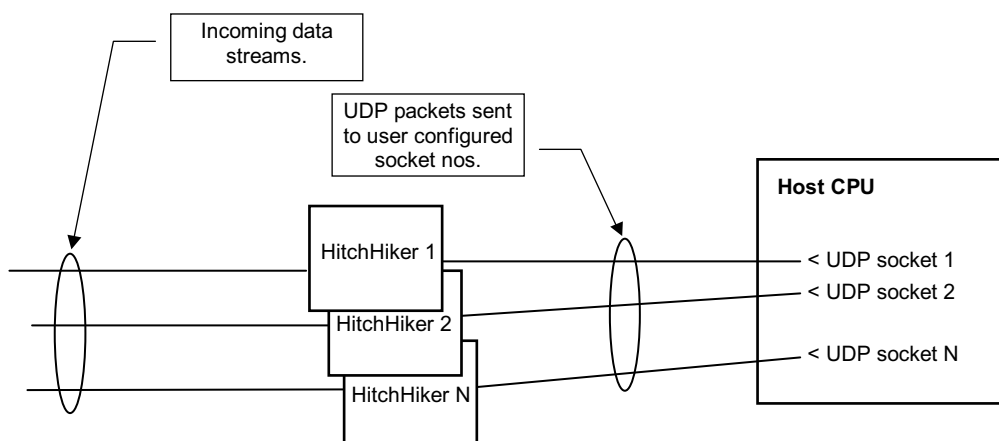

### To make a raw UDP link-

- 1) Use Main menu 2 - Configure unit, to enter and save an IP number for the unit, an IP number of the default gateway and a sub-net mask.
- 2) Use main menu item 1 - Set up Link
  - enter the IP number of the source unit
  - enter its password
  - enter the source port number- only ports 1 or 2, the RS232 ports, are applicable.
  - enter the name of the destination unit in the special form- **UDP IPno SKTno**  
e.g. to make a raw UDP link to UDP socket 7200 on host 152.48.158.39 enter **UDP 152.48.158.39 7200** (the spaces are important).
- 3) Save the setting. Notice that the link information for the port now shows; Port name → UDP -> 7200 is linked to -> 152.48.158.39

## Notes -

- If the host computer wishes to send data back to the HitchHiker it should send to UDP socket 6000 for serial port 1, or 6001 for serial port 2. NB: HitchHiker discards incoming network packets that are over 400 bytes long.
- To make a bi-directional raw UDP link between two HitchHikers, it is necessary to make a link on each unit pointing to the appropriate socket number on the other.
- Use socket numbers in the range 256 to 31999. (HitchHiker 'normal mode' packets use 8500 for both the source and destination sockets numbers).
- If you link to a UDP socket on your host that is not in use by some process, it may respond with an ICMP 'destination unreachable' message. HitchHiker ignores these.
- There is no end to end flow control when using raw UDP links. The receiving equipment must remove the incoming packets as quickly as they arrive.

## Multicasting raw UDP packets. (V1.44g onwards)

HitchHiker can also be configured to Multicast 'raw' UDP packets; a variation on the theme above. Use this type of configuration to multicast data to a number of host CPUs–

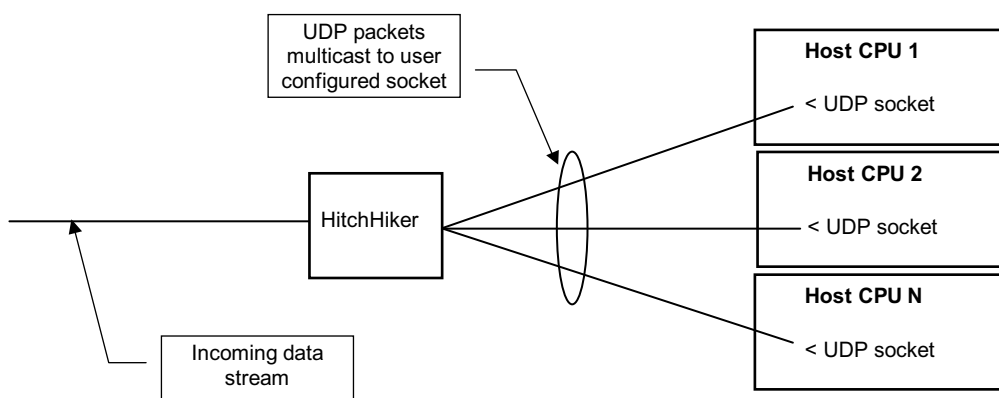

## To make a raw UDP Multicast link-

### 1) Use main menu item 1 - Set up Link

- enter the IP number of the source unit
- enter its password
- enter the source port number- only ports 1 or 2, the RS232 ports, are applicable.
- enter the name of the destination unit in the special form- **UDP MULTI SKTno**  
e.g. to make a raw UDP Multicast link to UDP socket enter  
**UDP MULTI 7200** (the spaces are important).

3) Save the setting. Notice that the link information for the port now shows;  
Port name → UDP → 7200 is linked to → MULTI

## Notes -

- If the host computer wishes to send data back to the HitchHiker it should send to UDP socket 6000 for serial port 1, or 6001 for serial port 2. NB: HitchHiker discards incoming network packets that are over 400 bytes long.
- Use socket numbers in the range 256 to 31999.
- If you link to a UDP socket on your host that is not in use by some process, it may respond with an ICMP 'destination unreachable' message. HitchHiker ignores these.
- There is no end to end flow control when using raw UDP links. The receiving equipment must remove the incoming packets as quickly as they arrive.

### Serial port configuration.

The factory default settings for the two serial ports are 9600 baud, 8 data bits, No parity, 1 stop bit, Xon/Xoff controlled output port. This sub-menu allows setting baud rates in the range 110 to 38K4, 7 or 8 data bits, odd, even or no parity, 1 or 2 stop bits.

### Output character delay (V1.36 onwards).

The serial port configuration sub-menu also allows an inter-character delay of between 0 and 255msec (approximate timings) to be selected. The effect of setting a value other than 0 is that HitchHiker waits for the chosen delay time between outputting characters to the serial port, slowing down the data stream. This may be useful when connecting a HitchHiker to equipment that can be overrun by a continuous stream of characters.

### Serial port handshake, or flow control.

Whenever you make links between units using the serial ports it is important to set up the handshake correctly. To do this, enter main menu '2 – Configure unit' and then select either serial port. A list of serial port configurable items is shown; handshake is item 5, which offers seven options-

1. Hardware
2. Input generating Xon/Xoff
3. Output responding to Xon/Xoff
4. Bi-directional Xon/Xoff
5. TISL logger keep alive
6. DTR/DSR direct end to end (plus one of the above)
7. Turn off end to end direct

The first two options allow HitchHiker serial ports to generate handshakes to stop and start data flowing into itself -

- By raising and lowering its CTS output- select 'Hardware' handshake
- By sending Xon and Xoff characters- select 'Input generating Xon/Xoff' handshake

HitchHiker can respond to handshakes from equipment trying to stop and start the data flowing out of a serial port in two ways -

- By monitoring the incoming RTS signal- select 'Hardware' handshake
- By looking for incoming Xon and Xoff characters- select 'Output responding to Xon/Xoff'

Use option 4 - Bi-directional Xon/Xoff, if you want a serial port to both- respond to Xon/Xoff characters and also to generate them to control data flow into itself.

Use option 5 – TISL logger keep alive, when connecting a serial port to a TISL call logger. This type of system periodically sends a keep alive string, >>OK to indicate that it can accept data. A HitchHiker serial port set to handshake option 5, will stop outputting data if it does not receive a keep alive string at least every 10 seconds.

Options 6 and 7 are described below. The factory default for both serial ports is 'Output responding to Xon/Xoff'.

*Important note about serial ports 1 & 2 - even if you choose 'Output responding to Xon/Xoff' flow control method, data is not allowed out of the serial port until RTS (into the port) is true. Link it to +12v (pin 6 to pin 7) or ensure the connected equipment is asserting it.*

### End to end flow control. (V1.43k onwards)

The serial ports may be set up so that the state of the DTR input (pin 4) on the source unit is passed to the DSR output (pin 6) of the destination unit. Likewise, the state of the DTR input on the destination unit is passed back to DSR output on the source unit. This is in addition to whatever handshake method has been chosen. In this way the link passes not just data each way, but the state of a control signal too. To set this option enter 'Configure Hardware ports', specifying the unit name, password and port number, and then enter the 'Handshake' menu selection. First select the flow control method you require, and then select 'DTR/DSR direct end to end (plus one of the above)'. Save the settings, and then perform the same configuration steps on the second unit in the link.

Notes -

1. Remember to save the changes before you exit.
2. Incorrectly set handshakes result in data loss.
3. Remember that RTS into the serial ports must be TRUE to allow data to flow.

#### Parallel port configuration.

This sub-menu allows selection of whether the parallel port is to be an input or output and whether it is to be Centronics standard (normal) or Data Products standard (usually found on high speed line printers). If in doubt select Centronics. The factory default is 'Output Centronic port'. Handshakes are handled automatically by the unit in all cases.

#### Changing packet send parameters.

Whenever data enters a serial port the unit has to make a decision about when to create a data packet and send it out to the network. You can adjust four settings that effect this-

- The time the unit waits since the last data packet was sent.
  - The time it waits after the last character was received from the RS232 port.
  - The number of characters to be sent in each packet.
  - Specify that a special character causes the packet to be sent.
1. The time the unit waits since the last data packet was sent. (M.38 onwards)

An internal timer relating to each serial input port counts down approximately every millisecond. If there is data waiting to send when it reaches zero, the data is formed into a packet and sent.

Valid choices for this value are 0 = nevertime out, 1 = 1ms, up to 127 = 127msec.

2. The time it waits after the last character was received from the RS232 port.

Alternatively, you can choose to wait to see if more data is coming into the serial port before sending the packet. In this case the port timer is reset to the full value each time a character is received, but if it reaches zero, any characters waiting are formed into a packet and sent. The entered figure must be multiplied by 10 to give an actual time in msec.

Valid choices for this value are 0 = never time out, 1 = 10ms, up to 127 = 1270msec.

3. The number of characters to be sent in each packet.

This setting allows you to choose the quantity of data which causes a data packet to be sent. The default is 256 bytes. When the chosen number of characters are present they are formed into a packet and sent. Valid choices for this value are from 1 to 256 bytes. This setting overrides the timeout settings, in that the unit never waits any longer once the chosen number of bytes are present.

4. Specify that a special character causes the packet to be sent (V1.39 onward).

This setting allows you to tell HitchHiker to look for a special character arriving into the port. When it is seen the waiting characters are formed into a packet, with the special character on the end and output to the network. For example, use the value 10 (line feed) to send each line of text in its own packet. Valid

choices for this setting are 000 to 253 decimal. 255 = no special character. The value 254 is used to optimise performance for the Andover Control Protocol (ACP).

Note - each input port is independent i.e. it is using its own copies of these parameters, but the values you select apply to all the input ports.

### Statistics.

From the main menu a 'Display Statistics' menu selection provides a screen, mainly for diagnostic purposes, showing the packets sent and received by the local unit. Counts of total packets, and counts of different types of packets used in the protocol, are shown.

### Contact sense inputs and Relay outputs.

Contact sense inputs and transistor driver outputs may be selected as a configuration option when ordering and provides -

- Four optically isolated input signals, suitable for sampling for example, a relay or switch contact
- Four open collector transistor outputs, each suitable for driving a relay coil.

The user can read the digital inputs at any HitchHiker by using the menu system. This can also be used to read and change the states of the four outputs signals. In this way the user can monitor and control all the digital I/O on any unit from any unit. For example, use a relay to control the mains power to a piece of equipment and then, from any remote HitchHiker-

1. cycle the power in the event of a lock up
- OR
2. remotely turn on an equipment,
  3. perform a function,
  4. read the results,
  5. turn it off again.

To use the menu system enter 'Configure Hardware ports', specifying the unit name, password and 'Configure Digital I/O port'. This screen shows the last recorded state of the four input lines and the last state that the four output lines were set to. It also offers the user the ability to set the states of the output lines to 'high' or 'low'. The 'U - Update unit' option actions any changes to the digital outputs which you have made, and then re-reads the inputs. Notice that the output lines are not changed until you perform the 'Update', so you can abandon without changes, by pressing ESC.

### Links between digital I/O ports (V1.34 onwards).

The user can set up logical 'links' between the digital I/O on two units. This links the four inputs on one unit to the outputs on another, and vice versa. Thus the states of the outputs reflect the states of the remote unit's inputs. Changes of the input signals trigger the linked outputs to be updated. For example, use this feature so that remote alarm outputs can be presented locally, or to allow local controls to be activated remotely and so on.

Use the main menu selection 1 - 'Set up a link' as normal, but choose port 4 to select the digital inputs of the source unit, then choose destination port 4 to select the digital outputs of the destination unit. Press Save. All changes of state at the digital inputs are sent to the destination unit to be mirrored on the digital outputs.

This logical link of inputs on one unit to outputs on another complements the Main menu 2, 'Configure Unit' option 4, 'Configure Digital I/O port' which allows the states of the inputs to be examined and the outputs states to be changed. Note that both these actions apply to the unit named when using main menu 2 - they do not apply to any unit linked to by that unit.

### Embedded command strings (V1.35 onwards).

Embedded command strings allow the unit to make and break links between units by entering simple strings into either of the serial ports. They are principally intended to be used in automated environments where the normal user interface is not appropriate.

The commands all begin with an 'arming string' of between 1 and ten user entered characters. Use any string of characters that will not occur naturally in your data.

Main menu 2, 'Configure Unit' option 'A', allows you to enter an arming string. You may enter any printable character directly from the keyboard, or the decimal ASCII value of the character you require preceded by a backslash. E.g. \010 = line feed, \013 = Carriage return, \\ = single backslash. E.g. enter FRED\\SUE\007\ results in FRED\SUEding! (\007 is the bell character).

#### The embedded command set.

Note- in the following {AS} represents any string of up to ten characters e.g. ~#!+z

Connect -                    {AS}C<IP number>P<port number>  
Disconnect -                {AS}D  
Forced disconnect -        {AS}X  
Enter menu system -        {AS}N (only applies to port 2)

Apart from {AS}N, which can only be used on port 2, the commands apply to the source unit and source port where they are received.

#### Examples -

A connect command {AS}C1.2.3.4P1 (no spaces) arriving at port 2 of a unit, will link port 2 of that unit to port 1 on the unit with IP number 1.2.3.4. This command acts like main menu 1, 'Make a link' and it can also be used to link the two serial ports to each other; enter the unit's own IP number.

The disconnect command {AS}D disconnects any link from the unit and port where it enters. This is like entering 'NONE' as the destination unit in the 'Make a link' menu.

The forced disconnect {AS}X is the same as {AS}D but is executed as soon as it is received and also flushes the port buffer where it is entered.

The enter menu command {AS}N only applies to serial port 2, and enters the menu system. Acts like typing ++++ into port 2.

#### Embedded command responses.

The unit can be set to send responses back to the port where embedded commands enter. The responses are -

**Armed-**                    on seeing the valid arming string,  
**Armed-OK**                valid arming string and the command is accepted.  
**Armed-Error1**            valid arming string, but the command is not recognised.

The remainder apply to the 'connect' command-

**Armed-Error2**            valid arming string, but the IP number is too long.  
**Armed-Error3**            valid arming string, but the IP number is badly formatted.  
**Armed-Error4**            valid arming string, but the port number is not 1, 2 or 3.

The responses can be toggled ON or OFF as required, using the submenu where the arming string is entered.

#### Changing the menu mode trigger character. (V1.37 onwards)

The unit responds to a repeated character entered at typing speed into port 2 by entering the menu system. The default character is +. Main menu 2, submenu B allows the selection of any single printable character to perform this function. If you enter CR (no trigger character) port 2 becomes completely transparent. Enter menu mode by pressing the recessed front panel push button.

- Layout of the rear panel connectors on the Mark 3 unit.

1) The diagram below shows the positions of the ports on a standard Mk3 HitchHiker unit. Although both are shown, normally only one network port is fitted.

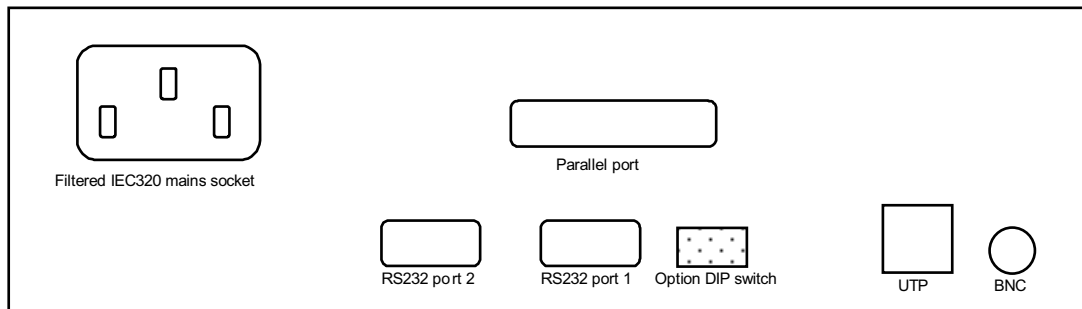

2) The diagram below shows the positions of the ports on a fully configured Mk3 HitchHiker unit. All these ports may not be fitted to your unit, depending on the options ordered.

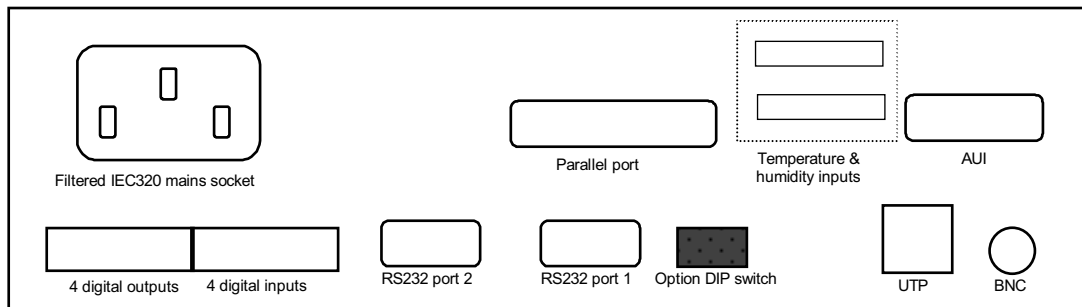

The following section details the connectors and signal assignments, with some notes about how to use each of the ports.

Serial port pin connections.

Factory default DCE configuration-

Signal name	Serial port 1	Serial port 2
DCD out of unit (+12v)	1	1
Data out of unit	2	2
Data into unit	3	3
DTR into unit *	4	4
Signal ground	5	5
DSR out of unit *	6	6

RTS into unit	7	7
CTS out of unit	8	8
N/C	9	9

\* If end to end handshake is used, DTR is passed to DSR on the linked unit.  
Pins labelled +12v are permanently asserted in the true state.

Optional DTE configuration -

To set this configuration, disconnect the unit from the mains power, and open the unit. DCE/DTE links are found next to the serial connectors. Labelling on the printed circuit board shows the link positions.

<u>Signal name</u>	<u>Serial port 1</u>	<u>Serial port 2</u>
DCD into unit (ignored)	1	1
Data into unit	2	2
Data out of unit	3	3
DTR out of unit *	4	4
Signal ground	5	5
DSR into unit *	6	6
RTS out of unit	7	7
CTS into unit	8	8
N/C	9	9

\* If end to end handshake is used, DSR is passed to DTR on the linked unit.

Parallel port pin connections.

Factory default setting is Centronics output port -

<u>Centronics signal names.</u>	<u>Output port direction.</u>	<u>Input port direction.</u>	<u>Pin number</u>	<u>Data Products signal names.*</u>
/strobe	out	in	1	strobe
data bit 0	out	in	2	da0
data bit 1	out	in	3	da1
data bit 2	out	in	4	da2
data bit 3	out	in	5	da3
data bit 4	out	in	6	da4
data bit 5	out	in	7	da5
data bit 6	out	in	8	da6
data bit 7	out	in	9	da7
/acknowledge	in	out	10	N/A
busy	in	out	11	demand
paper end	in	out	12	N/A
select	in	out	13	N/A
n/c			14	n/c
/fault	in	out	15	N/A
/init	in	out	16	N/A
/select	in	out	17	N/A
ground	-	-	18-25	ground

\* Note - this is a minimum subset of the signals needed for Data Products interface support.

Option DIP switch settings.

MkIII HitchHiker is fitted with a DIP switch accessible on the back panel. The assignments are

<u>Switch no</u>	<u>Function</u>
1 off, 2 on	UTP

1 on, 2 on	BNC
1 on, 2 off	AUI
3 on	reset to factory defaults ('cold' start)*
4	reserved
5	reserved
6 on	reset to factory defaults (factory or 'very cold' start) **

\*Switch on and then power up the unit. After a few seconds switch to off again. The factory default name is **HitchHiker** and the password is **pass**.

\*\*NB: switch 6 only applies to units fitted with the Enhanced Protocol support (which use Flash ROM). **WARNING - do not do a 'very cold start'** unless you are prepared to TFTP a copy of the operational firmware to the unit. (TFTP is a simpler version of FTP, the file transfer protocol). The firmware is provided as a file called HHTFTP.BIN. Note that the IP number defaults to **1.1.1.44**

Restoring factory defaults.

Two methods are provided to restore factory settings-

1. By DIP switch - disconnect the unit from the mains power, set DIP switch 3 on. Turn the power to the unit on and after a few seconds reset switch 3 back to the off position.
2. Using the menu system -
  - 2.1 On standard units; enter 'Configure unit', specifying name or IP number of the local unit. Enter the password, and then use the 'Restore factory defaults' menu selection. All settings including the IP number of the unit are reset to the factory default values.
  - 2.2 On units fitted with the enhanced protocol support pack; enter 'Configure unit', specifying name or IP number of the any unit. Enter the password, and then use the 'Reset and Restore factory defaults' menu selection. The unit restarts, restores all settings to the factory default settings *except* the three IP numbers, which are preserved (IP of unit, IP of default gateway, sub-net mask). This allows the user to reset any unit on the network without losing its IP numbers.

Digital I/O port connections (Optional feature).

Pin outs of the two part screw connectors for the digital I/O-

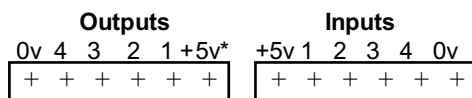

\* may be set to +12v by internal link.

Use of the digital inputs and outputs -

The four input lines are optically isolated. An example of how to drive these pins from a 'voltage free dry contact' e.g. a switch or relay contact, is shown below-

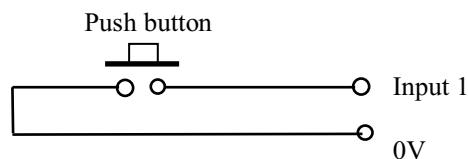

Four outputs lines are open collector transistors. An example of how to use these to drive the coil of a relay is shown -

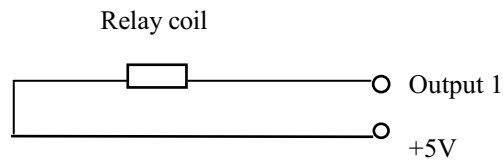

Notes: -

1. The +5Vdc output should not be loaded with less than 50 ohms as this power is the main +5V for the HitchHiker circuitry. An excessive load will cause the internal +5V regulator to fold back and the unit will not function.
2. An internal link allows selection of +5V or +12v on pin 6 of the digital output socket.

Temperature and humidity measurement.

Analogue input ports can be specified which are designed to connect to external temperature and humidity modules. Up to four modules can be connected. An SNMP workstation can be used to monitor the temperature and humidity at the remote location. In addition the unit can be configured to send SNMP traps when temperature or humidity inputs exceed set limits. See addendum 1 for more details about the use of SNMP.

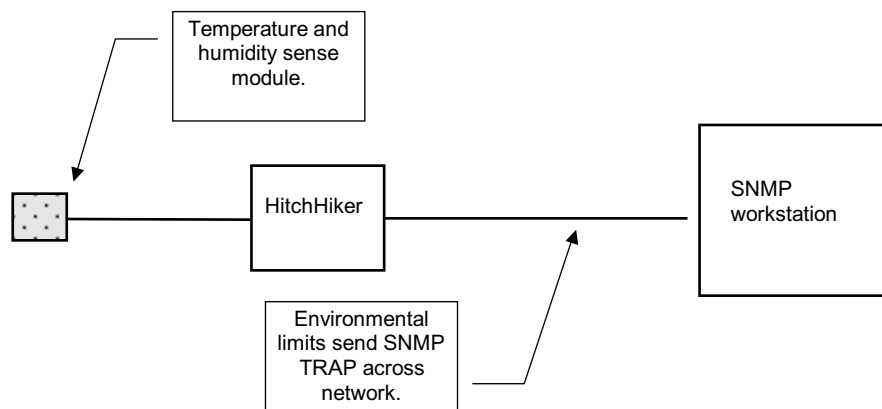

Pin out of the analogue input connectors.

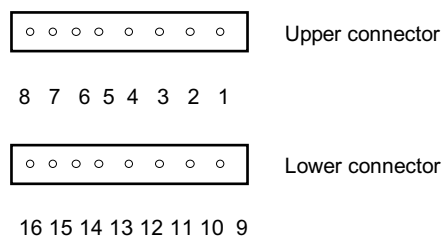

Pin assignments -

Pin no.	Function (upper connector)
1	Relative Humidity input 1
2	0v
3	Temperature input 1
4	Power to sensor
5	Relative Humidity input 2
6	0v
7	Temperature input 2
8	Power to sensor

Pin assignments -

<u>Pin no.</u>	<u>Function (lower connector, if fitted)</u>
9	Relative Humidity input 3
10	0v
11	Temperature input 3
12	Power to sensor
13	Relative Humidity input 4
14	0v
15	Temperature input 4
16	Power to sensor

Connect Temperature and humidity sense module(s) to the connectors, carefully noting the pin outs above. The top connector can connect two sense modules and the lower connector can connect one. The last two analogue inputs on the lower connector are reserved.

To calibrate temperature, measure the ambient in the region of the sensor, using an independent thermometer and enter the value read into the SNMP MIB item 'Temperature correction'. Upper and lower limits can be set on all inputs, and traps will be generated if they are exceeded. A further trap is generated each time the measured input exceeds the limit by a further amount. A return to normal trap is sent when the measured value returns into the normal region.

#### General comments about HitchHiker.

##### Using HitchHiker with bridges and routers.

Ethernet bridges learn where the various MAC addresses on your network are and forward packets accordingly. They will normally forward all HitchHiker packets perfectly, but some bridges allow filtering of packets based on certain criteria, for example broadcasts and multicasts can be discarded. If Multicasts are disabled, menu option 3, 'display units on line', will not display units on the far side of the bridge. The same applies to routers and intelligent hubs. They will rarely pass broadcasts or multicasts, so units on the far side of them will not be seen by menu option 3. The HitchHiker protocol is fully TCP/IP compliant, and allows any unit on the WAN to be-

1. Pinged.
2. Linked to any other unit.
3. Have its configuration examined and modified

However, units on different sub-nets of a WAN must be referred to by IP number not name, and valid entries for IP number, default gateway IP number and subnet mask must be entered into all units. Refer to your network administrator.

##### HitchHiker's use of UDP.

HitchHiker uses UDP as the data transport and embeds its own protocol within it. HitchHiker uses the UDP source and destination socket numbers of 8500 (unless you have configured the unit to send raw UDP packets).

##### HitchHiker's keep alive heartbeat.

HitchHiker generates a 'heartbeat' packet addressed to itself every 30 seconds or so. This is so that the unit can recover from unexpected lock ups and complements the hardware watchdog circuit. Should the unit not receive any network traffic for a few minutes it will allow the watchdog circuit to reset the unit. *NB:* If you enter the menu system on a UTP unit that is not plugged into a hub, it will reset itself every few minutes and appear to have 'dropped out of menu mode'. Thisnet units can see their own heartbeat packets without being connected to a network.

##### HitchHiker's effect on Ethernet traffic.

Apart from the 'heartbeat' packet, HitchHiker only sends network packets when data arrives on its serial or parallel ports. If data arrives slowly, say at typing speed, each character may be sent singly in its own packet. If data arrives faster, many bytes (the factory default is 256) share one packet. Every packet is acknowledged by the receiving unit. Flat out serial data at 38k4 baud produces 256 bytes in 64ms which equates to about 160 data packets and 160 ack packets per second. This is a very low packet rate compared to most other network attached devices.

## Specification.

RS232C ports - speeds up to 38.4k baud, 7 or 8 data, 1 or 2 stops, odd, even or no parity. Presented on D9 male connectors which support Txd, Rxd, RTS, CTS, signal ground, DCD and DTR.

Parallel port - can be set as a parallel input or output port and supports both the Centronics and Data Products printer standards. Indicator led confirms the selection. Presented on D25 female connector.

General I/O - four optically isolated inputs suitable to detect a relay closure or a signal level and four TTL outputs suitable to drive a relay coil etc. This is an optional feature.

Analogue input ports - four pairs of inputs suitable to connect to external temperature/humidity modules. Relative humidity range 30-90%, accuracy  $\pm 5\%$ . Temperature in Centigrade. Range 0-60, accuracy  $\pm 2$  degrees. This is an optional feature.

Network port - 10Mbit/s Ethernet presented on either 10baseT (UTP) - 100m/segment, 10base2 (BNC or 'thin net') - 185m/segment, or AUI port. The power led shows which type of network is in use.

Network protocols - IEEE 802.3 Ethernet encapsulates IP packets, as defined in RFC 894. IP, UDP, ARP, ICMP (ping), TFTP\*, SNMP\* and IGMP level 2 \* protocols are supported.

\* These protocols are supported by the Enhanced Protocol Support option.

Power supply - the units are powered by an internal mains PSU requiring 240VAC, 50Hz @12W. The mains connector is a filtered IEC320 type to ensure compliance with EMI/RFI standards. A 110Vac, 60 Hz power supply is available.

Indicators - LEDs are provided for each port -

- LAN port:- Tri-colour red/green shows BNC or UTP selected Also acts as power on led.
- Traffic - LEDs for transmitted and received packets.
- Serial ports:- LEDs for Tx data, Rx data. Port 2 has a 'command mode' led.
- Parallel port:- LEDs for Tx data, Rx data and red/green led for Centronics or Data Products interface standard selected.

Push Button - to enter command mode.

User settings are all saved in internal non-volatile memory.

Enclosure - all metal case with electrically bonded panels ensure compliance with EMI/RFI standards. Size - Length 262mm, Width 218mm, Height 70mm (1.5U). Weight 1.5Kg. Mounting arrangements - table top, stacking. Optional rack mounting kit.

Environmental - 0 to 40 degrees centigrade, 5 to 95% humidity (non-condensing).

## Addendum 1

### Enhanced protocol support pack. Optional feature.

- SNMP support.
- Local processing - Boolean logic equations.
- TFTP Upgrade option.
- IP broadcasting and IGMP

### Hardware options -

- The expansion relay I/O option.
- -48Vdc power supply option.

- SNMP support.

HitchHiker offers support for the Simple Network Management Protocol, one of the members of the TCP/IP suite of protocols. Using an SNMP client, for example HP Open View, the user can examine and modify the operating parameters of the unit. Additionally, HitchHiker may be configured to send SNMP traps for various reasons.

The client software must be configured with the Management Information Base (MIB) supported by the SNMP agent software running in HitchHiker. The MIB is provided on a DOS diskette in simple ASCII text form ready to be loaded into the management station, and results in a newtree being added under the 'private.enterprises' section of the MIB named 'Mutek'. The portions of the MIB supported by HitchHiker are shown pictorially below-

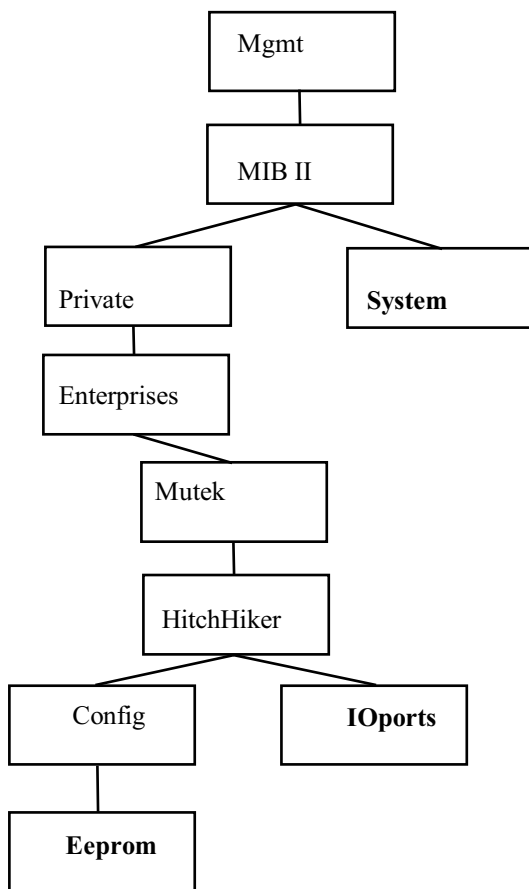

#### Setting up to use HitchHiker with SNMP.

1. Whenever using HitchHiker, it is first essential to connect a terminal set to 9600 baud, 8, N, 1, to serial port 2 and use the menu system to enter a unit name and IP numbers. This is explained in the opening section 'Quick start for the impatient'. Type ++++ to enter command mode. Use main menu 2 to enter your chosen unit name, IP number, the IP number of the default router, and the subnet mask and Save these settings.
2. Using your SNMP client, set the IP number of the workstation that the unit must send its Traps to. MIB item 'TrapIP' below.

#### The Mutek enterprise MIB.

The 'System' part of the MIB shows the seven standard read only variables defined in MIBII.

The 'Eeprom' part of the Mutek MIB allows the user to manage the objects shown below.  
Objects relating to the main unit functions-

Macnumber - read-only, the value of the 'burned in' Ethernet number in the unit.  
Name - the unit name  
Password - the unit password (community)  
IPnumber - unit IP number  
RouterIP - the IP number of the default router  
MaskIP - the unit sub-net mask  
SPtrigger - unused  
Sptime, Spchar, SPcount - values to do with when to send packets. Please see section below.  
SerialPort1 - settings for serial port 1, see more below.  
SerialPort2 - settings for serial port 2, see more below.  
ParallelPort - settings for the parallel port, see more below.  
TrapIP1 - the IP number of the first management station that trap messages are sent to.  
TrapIP2 - the IP number of the 2nd management station that trap messages are sent to.  
TrapIP3 - the IP number of the 3rd management station that trap messages are sent to.  
TrapIP4 - the IP number of the 4th management station that trap messages are sent to.  
IGMPip1 - Multicast group IP number for serial port 1.  
IGMPip2 - Multicast group IP number for serial port 2.

Objects relating to local processing- Boolean logic functions -

andips1 - 32 input bits for AND equation 1.  
andops1 - 8 output bits for AND equation 1.  
andips2 - 32 input bits for AND equation 2.  
andops2 - 8 output bits for AND equation 1.  
orips1 - 32 input bits for OR equation 1.  
orops1 - 8 output bits for OR equation 1.  
orips2 - 32 input bits for OR equation 2.  
orops2 - 8 output bits for OR equation 1.  
inverter - Output bits INVERTER.

Objects relating to analogue sense inputs-

RH-1 - Relative Humidity input no.1.  
Temp1 - Temperature input no. 1  
RH-2 - Relative Humidity input no.2.  
Temp2 - Temperature input no. 2.  
RH-3 - Relative Humidity input no.3.  
Temp3 - Temperature input no. 3.  
RH-4 - Relative Humidity input no.4.  
Temp4 - Temperature input no. 4.  
temp-correct - Temperature Calibration.

High and low limits for the analogue inputs. Traps are sent if these are exceeded-

RH1-low - RH-1 low limit.  
RH1-hi - RH-1 high limit.  
Temp1-lo - Temp1 low limit  
Temp1-hi - Temp1 high limit  
RH2-low - RH-2 low limit.  
RH2-hi - RH-2 high limit.  
Temp2-lo - Temp2 low limit  
Temp2-hi - Temp2 high limit  
RH3-low - RH-3 low limit.  
RH3-hi - RH-3 high limit.  
Temp3-lo - Temp3 low limit

Temp3-hi - Temp3 high limit  
RH4-low - RH-4 low limit.  
RH4-hi - RH-4 high limit.  
Temp4-lo - Temp4 low limit  
Temp4-hi - Temp4 high limit  
Save-button - saves user changes and the current states of the outputs (OutPort1- 4 and OutPortA1 - 8) into flash memory.

Serial ports 1 & 2 and the parallel port support the following MIB items-

Name - port name.  
LinkMac - Mac number of the unit this port is linked to. FF = none, 7F = ARP refresh  
LinkPort - Port number on the unit that this port is linked to.  
LinkIP - IP number of the unit that this port is linked to  
TO - idle time out of the above link in 10ms units (eg. 200 = 200 x 10ms = 2 seconds)  
LinkName - text string description of the destination unit that this port is linked to.  
Baud - Baud rate of this port. (serial ports only)  
Format - Number of data bits, stop bits and parity of this port. (serial ports only)  
Flow - flow control method of this port. (serial ports only)  
Multiin - whether this port accepts one link or eight data links. (serial ports only)

The 'IOPorts' part of the Mutek MIB allows the user to manage-

InPort1 - read-only, the value read by onboard contact sense input 1.  
InPort2 - read-only, the value read by onboard contact sense input 2.  
InPort3 - read-only, the value read by onboard contact sense input 3.  
InPort4 - read-only, the value read by onboard contact sense input 4.

OutPort1 - the value being output to onboard relay drive 1.  
OutPort2 - the value being output to onboard relay drive 2.  
OutPort3 - the value being output to onboard relay drive 3.  
OutPort4 - the value being output to onboard relay drive 4.

OutPortA1 - the value being output to expansion option relay 1.  
OutPortA2 - the value being output to expansion option relay 2.  
OutPortA3 - the value being output to expansion option relay 3.  
OutPortA4 - the value being output to expansion option relay 4.  
OutPortA5 - the value being output to expansion option relay 5.  
OutPortA6 - the value being output to expansion option relay 6.  
OutPortA7 - the value being output to expansion option relay 7.  
OutPortA8 - the value being output to expansion option relay 8.

EXP-port1 - read-only, the values read by expansion option contact sense inputs 1- 8.  
EXP-port2 - read-only, the values read by expansion option contact sense inputs 9 - 16.  
EXP-port3 - read-only, the values read by expansion option contact sense inputs 17- 24.  
EXP-port4 - read-only, the values read by expansion option contact sense inputs 25- 32.

## Traps

HitchHiker generates Alarms or information messages when certain events occur as described below. These alarms or messages are sent in the form of SNMP Traps, and they can be sent to up to four workstations whose IP numbers entered into the mib 4 variables 'TrapIP1' to 'TrapIP4'. The traps are

## System Traps

The unit is powered up with no configuration file present = 'Cold start'  
The unit is powered up and adopts previously saved settings = 'Warm Start'

## I/O Expansion option Input Port Traps

Input port 1 changing state from LOW to HIGH = Trap 1  
Input port 1 changing state from HIGH to LOW = Trap 2  
Input port 2 changing state from LOW to HIGH = Trap 3  
Input port 2 changing state from HIGH to LOW = Trap 4  
Input port 3 changing state from LOW to HIGH = Trap 5  
Input port 3 changing state from HIGH to LOW = Trap 6  
Input port 4 changing state from LOW to HIGH = Trap 7  
Input port 4 changing state from HIGH to LOW = Trap 8  
Input port 5 changing state from LOW to HIGH = Trap 9  
Input port 5 changing state from HIGH to LOW = Trap 10  
Input port 6 changing state from LOW to HIGH = Trap 11  
Input port 6 changing state from HIGH to LOW = Trap 12  
Input port 7 changing state from LOW to HIGH = Trap 13  
Input port 7 changing state from HIGH to LOW = Trap 14  
Input port 8 changing state from LOW to HIGH = Trap 15  
Input port 8 changing state from HIGH to LOW = Trap 16

Input port 9 changing state from LOW to HIGH = Trap 17  
Input port 9 changing state from HIGH to LOW = Trap 18  
Input port 10 changing state from LOW to HIGH = Trap 19  
Input port 10 changing state from HIGH to LOW = Trap 20  
Input port 11 changing state from LOW to HIGH = Trap 21  
Input port 11 changing state from HIGH to LOW = Trap 22  
Input port 12 changing state from LOW to HIGH = Trap 23  
Input port 12 changing state from HIGH to LOW = Trap 24  
Input port 13 changing state from LOW to HIGH = Trap 25  
Input port 13 changing state from HIGH to LOW = Trap 26  
Input port 14 changing state from LOW to HIGH = Trap 27  
Input port 14 changing state from HIGH to LOW = Trap 28  
Input port 15 changing state from LOW to HIGH = Trap 29  
Input port 15 changing state from HIGH to LOW = Trap 30  
Input port 16 changing state from LOW to HIGH = Trap 31  
Input port 16 changing state from HIGH to LOW = Trap 32

Input port 17 changing state from LOW to HIGH = Trap 33  
Input port 17 changing state from HIGH to LOW = Trap 34  
Input port 18 changing state from LOW to HIGH = Trap 35  
Input port 18 changing state from HIGH to LOW = Trap 36  
Input port 19 changing state from LOW to HIGH = Trap 37  
Input port 19 changing state from HIGH to LOW = Trap 38  
Input port 20 changing state from LOW to HIGH = Trap 39  
Input port 20 changing state from HIGH to LOW = Trap 40  
Input port 21 changing state from LOW to HIGH = Trap 41  
Input port 21 changing state from HIGH to LOW = Trap 42  
Input port 22 changing state from LOW to HIGH = Trap 43  
Input port 22 changing state from HIGH to LOW = Trap 44  
Input port 23 changing state from LOW to HIGH = Trap 45  
Input port 23 changing state from HIGH to LOW = Trap 46  
Input port 24 changing state from LOW to HIGH = Trap 47  
Input port 24 changing state from HIGH to LOW = Trap 48

Input port 25 changing state from LOW to HIGH = Trap 49  
Input port 25 changing state from HIGH to LOW = Trap 50  
Input port 26 changing state from LOW to HIGH = Trap 51  
Input port 26 changing state from HIGH to LOW = Trap 52  
Input port 27 changing state from LOW to HIGH = Trap 53

Input port 27 changing state from HIGH to LOW = Trap 54  
Input port 28 changing state from LOW to HIGH = Trap 55  
Input port 28 changing state from HIGH to LOW = Trap 56  
Input port 29 changing state from LOW to HIGH = Trap 57  
Input port 29 changing state from HIGH to LOW = Trap 58  
Input port 30 changing state from LOW to HIGH = Trap 59  
Input port 30 changing state from HIGH to LOW = Trap 60  
Input port 31 changing state from LOW to HIGH = Trap 61  
Input port 31 changing state from HIGH to LOW = Trap 62  
Input port 32 changing state from LOW to HIGH = Trap 63  
Input port 32 changing state from HIGH to LOW = Trap 64

'Onboard Input' Port Traps are generated for changes of the 4 optically isolated inputs-

Onboard Input port 4 changing state from HIGH to LOW = Trap 65  
Onboard Input port 4 changing state from LOW to HIGH = Trap 66  
Onboard Input port 3 changing state from HIGH to LOW = Trap 67  
Onboard Input port 3 changing state from LOW to HIGH = Trap 68  
Onboard Input port 2 changing state from HIGH to LOW = Trap 69  
Onboard Input port 2 changing state from LOW to HIGH = Trap 70  
Onboard Input port 1 changing state from HIGH to LOW = Trap 71  
Onboard Input port 1 changing state from LOW to HIGH = Trap 72

HitchHiker front panel push button Traps

This feature is provided as a simple check that traps are operational and being seen by the management station. Note that pressing the push button also takes serial port 2 into command mode. To exit command mode enter ESC to serial port 2 or turn the unit off and on again.

Push button PRESSED = Trap 73  
Push button RELEASED = Trap 74

Analogue input high and low limits traps, and 'return to normal' traps -

RH1 LOW limit = Trap 75  
RH1 HIGH limit = Trap 76  
RH1 normal = Trap 77  
Temp1 LOW limit = Trap 78  
Temp1 HIGH limit = Trap 79  
Temp1 normal = Trap 80  
RH2 LOW limit = Trap 81  
RH2 HIGH limit = Trap 82  
RH2 normal = Trap 83  
Temp2 LOW limit = Trap 84  
Temp2 HIGH limit = Trap 85  
Temp2 normal = Trap 86  
RH3 LOW limit = 87  
RH3 HIGH limit = Trap 88  
RH3 normal = Trap 89  
Temp3 LOW limit = Trap 90  
Temp3 HIGH limit = Trap 91  
Temp3 normal = Trap 92  
RH4 LOW limit = Trap 93  
RH4 HIGH limit = Trap 94  
RH4 normal = Trap 95  
Temp4 LOW limit = Trap 96  
Temp4 HIGH limit = Trap 97  
Temp4 normal = Trap 98



All fields are represented as OCTET strings which means that they are shown as digit pairs with a range 00 to FF. Input fields are made up of four pairs to represent 32 inputs. Output fields are only one digit pair to represent 8 bits. Examples; 00 01 40 FF shows 10 input field bits set- 1 to 8 inclusive, bit 15 and bit 17. An output field set to 84 would affect relays 8 and 3. The inverter byte bits are the same as an output field.

Examples - 00 00 00 01 means look for contact input 1 to be set. 00 00 80 00 means look for contact input 16 to be set. 0B 00 00 00 means look for input contacts 2, 5, 6, and 28 to be set.

Note - Pressing the 'Save-button' - saves current states of the outputs (OutPort1- 4 and OutPortA1 - 8) into flash memory. When power is applied to the unit, the saved states of these outputs are reapplied to the hardware.

- TFTP Upgrade option.

HitchHiker optionally supports remote firmware upgrade by TFTP. Units with this option are fitted with 128Kb of flash memory which is sectored into a write protected boot block, two parameter blocks and a code block. To upgrade a unit simply TFTP the new firmware to the IP number of the target device. The remote unit will validate the incoming file (checksum and name check) and then reprogram its code block.

Normal power on sequence.

Every time the unit is powered up the boot block validates the code block by checksum. If it passes the check the boot block transfers control to the code block and normal HitchHiker functions begin. The LEDs indicate what is happening-

1. On power up - LAN Tx and Rx ON and serial port 1 Tx and Rx LEDs flash 1/sec - the unit is checking its program. This takes a few seconds.
2. LEDs adopt normal settings - the unit is running.

HitchHiker is running normally- how to upgrade the firmware.

The TFTP protocol is a simple version of FTP which is commonly used by embedded controller devices such as HitchHiker to upgrade their internal firmware stored in Flash ROM. HitchHiker firmware is provided as a file called HHTFTP.BIN. It is 112k long and has a Fletcher checksum in the last two bytes. To upgrade (or resurrect) a HitchHiker, this file must be uploaded to the unit using TFTP. (TFTPC by Weird Solutions is a very compact, efficient application to allow Win95 to perform TFTP PUTS and GETS. It is available on the Internet as a file called TFTPC.ZIP (42kb long). It is required to be licensed.)

In the event that a unit is to be upgraded with new firmware, proceed as follows-

1. LEDs are showing normal HitchHiker settings- the unit is running normally.
2. PING the unit to verify the IP number and that the unit is connected and functioning normally.
3. Send the program file HHTFTP.BIN to the unit using TFTP - serial port 1 Tx and Rx LEDs start FLASHING. HitchHiker loads the program into its internal ram memory. The download takes typically 10 secs on 10Mb Ethernet, but can take minutes on a slow WAN.
4. Serial port 1 Tx and Rx LEDs FLASHING - The download is complete and HitchHiker is checking the Fletcher checksum of the new program in its ram memory. This takes about 10 secs.
5. Serial port 1 and serial port 2 Tx and Rx LEDs ON - HitchHiker has verified that the program has been received correctly and the Flash ROM chip is now being programmed. This takes about 10 secs.
6. LAN Tx and Rx ON, serial port 1 Tx and Rx LEDs FLASHING - HitchHiker has completed programming the Flash ROM and has restarted; it is checking the newly programmed Flash ROM. This takes about 10 secs.
7. LEDs adopt normal HitchHiker settings- program is running.

Notes - HitchHiker will only accept the program named HHTFTP.BIN, which must be in capitals. Also the file cannot be patched as this will cause the checksum to fail.

### The HitchHiker program is corrupted- steps to take.

Various fault scenarios can require the program file (HHTFTP.BIN) to be sent to a unit

1. When upgrading a unit, the program is corrupted during the download. Step 4 above will detect this.
2. When checking the new program in Flash ROM, step 6 above detects a problem.
3. When it is powered up HitchHiker finds that there is a problem with the program in its Flash ROM.

The above problems are shown by serial port 1 Tx and Rx LEDs flashing continuously. HitchHiker contains a write protected kernel which supports PING and TFTP, and this allows the unit to be brought back to full functionality. Follow the steps from number 2, as described above.

### Notes on factory defaults and the TFTP option.

With the TFTP upgrade option, all user settings are held in Flash memory, and they can be restored at two levels. The factory defaults are-

IP number - 1.1.1.44	Serial ports - 9600 baud, 8, N, 1, Xon/.Xoff, input port
Default gateway IP number - 1.1.1.100	Parallel port - Centronics output
Sub-net mask - 255.255.255.0	Trigger character to enter command mode is +
Password - pass	Embedded code arming string is off.
Name - HitchHiker	Network packets - 256 bytes long, sent when 100ms elapses since last received character.

### 'Very Cold start' - factory use to initialise user settings.

At the factory the boot kernel is made to copy the default settings from itself (read only) into both the 'Cold' and 'Warm' parameter blocks, by setting dip switch 6 to ON. This also prevents the unit from running normal HitchHiker code, so switch DIP switch 6 off a few seconds after power up

1. Turn DIP switch 6 ON
2. Power the unit ON
3. HitchHiker kernel does Very Cold start- wait a few seconds and turn DIP switch 6 OFF
4. Ping the unit to verify operability and the IP number.
5. Send HHTFTP.BIN to the unit using TFTP.
6. Serial port 1 and serial port 2 Tx and Rx LEDs On- flash being re-programmed.
7. LAN Tx and Rx On - boot block is validating the newly programmed code block.
8. LEDs adopt normal HitchHiker settings- code is running.
9. Now perform a normal 'Cold Start' as described below-

### 'Cold start' - user re-initialises default settings.

At any time the user can copy the Cold settings into the Warm settings by setting dip switch 3 to ON.

1. Turn DIP switch 3 ON
2. Power the unit ON - Serial port 1 Tx and Rx LEDs flash 1/sec- boot block is running.
3. LAN Tx and Rx On - boot block is validating the code block. This takes a few seconds.
4. HitchHiker does Cold start and LEDs adopt normal HitchHiker settings- code is running.
5. Turn DIP switch 3 OFF

### The memory map of a HitchHiker with the TFTP upgrade option.

Top of memory	128k Flash	8k write protected Boot block, holds the program kernel
		4k 'warm' parameter block for user settings
		4k 'cold' parameter block for default user settings
		112k main HitchHiker program block
	Unused	384k

Bottom of memory	RAM	128k
------------------	-----	------

## IP Broadcasting and IGMP (V1.53 onwards).

HitchHiker has long provided Ethernet multicasts, which allows a serial data stream to be broadcast to many HitchHikers on the same sub-net. IGMP (internet group management protocol) protocol allows HitchHiker to broadcast RS232 data to selected units, anywhere on the network using a standard IP protocol supported by all good quality routers. Using IGMP level 2, you each RS232 port can broadcast to a separate group of HitchHikers.

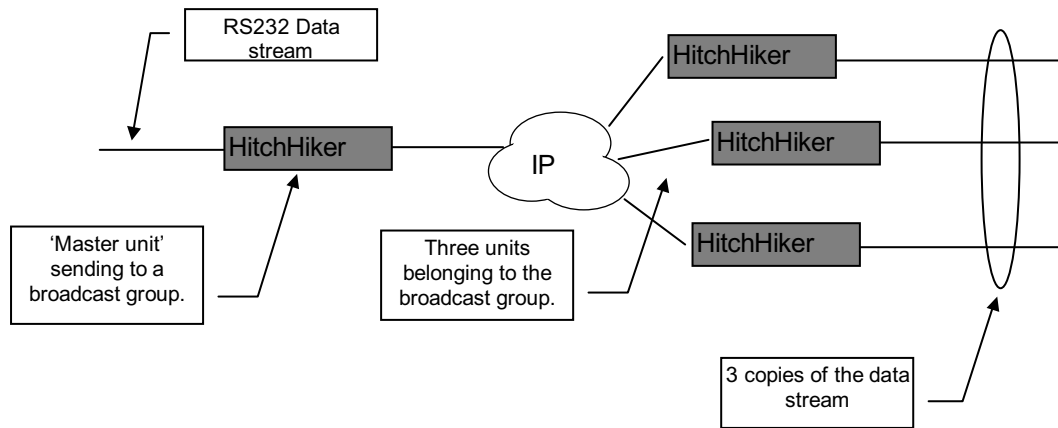

IP broadcasting relies on using a special range of IP numbers reserved by the IP numbering committee (IANA), in the range 224.0.0.0 to 239.255.255.255. These IP numbers correspond to a block of ethernet (MAC) addresses in the range 01:00:5e:00:00:00 to 01:00:5e:7f:ff:ff. The HitchHiker menu system checks for this range of IP addresses and performs the necessary translation to ethernet addresses.

IP broadcasting relies on the network routers to perform IGMP in order to discover devices belonging to IP broadcast groups. It does this by sending IGMP queries and receiving back the IGMP responses from devices reporting their group membership. HitchHiker may be configured to join broadcast groups (described below), and will then respond to router IGMP requests appropriately.

HitchHiker configuration can be performed using the menu system or SNMP, as described below.

### Configuration for IP Broadcast using HitchHiker Menus.

For example, to set serial port 1 on a master unit to broadcast to a group of units on the broadcast IP number 224.1.2.3, proceed as follows -

Setting up the broadcasting unit -

- Use main menu item **1 - Set up Link**, and enter the IP number of the master unit and its password.
- Enter the port number that is to broadcast. 1 in this example.
- Enter the broadcast IP number, 224.1.2.3 as the name of the destination unit.
- Choose an idle time out or press enter to accept the 20sec default.
- Press S to save these settings.

Notes -

- Valid IP numbers for IP multicast groups are in the range 224.0.0.0 to 239.255.255.255, so when you enter a number in this range as the 'destination unit', HitchHiker *automatically* sets itself up to perform IP broadcasting.
- The broadcasting unit does not need to join the broadcast group, and in fact it has not joined one in the above example - it has simply been told to send to one.

Units that should receive the broadcast data must be set to join the broadcast group, as follows.

Setting up units to join the broadcast group-

- Use the main menu item **2 - Configure Unit**, enter the IP number of the unit and its password.
- Enter the number of the port joining the broadcast group; 1 or 2 (the parallel port cannot be used).
- Use sub-menu **6 - Rename Port** and enter the example broadcast group IP number as follows: IGMP 224.1.2.3 (one space between the letters IGMP and the IP number).
- Press S to save these settings.

Perform the steps above on each unit/port which you wish to receive data broadcast by the master.

Notes -

- The port name now appears as IGMP, but if the unit configuration is examined (main menu 2), it can be seen that the port reports itself as - named IGMP group 224.1.2.3 - destination port.
- Data arriving at a port which is a member of a broadcast group is automatically sent back to the master unit. It is not necessary to set reverse links on these ports.

#### Configuration for IP Broadcast using SNMP.

For example, to set serial port 1 on a master unit to broadcast to a group of units on the broadcast IP number 224.1.2.3, proceed as follows-

On the master (sending) unit-

1. Using your SNMP workstation enter the IP broadcast group number 224.1.2.3 into the OID 'IGMPip1' (The OID 'IGMPip2' is for serial port 2)
2. Set the remaining SerialPort1 values as follows -

LinkMac = 01 00 5e 01 02 03\*

LinkIP = 224.1.2.3

LinkName = '224.1.2.3'

\*The LinkMac number is composed as follows-

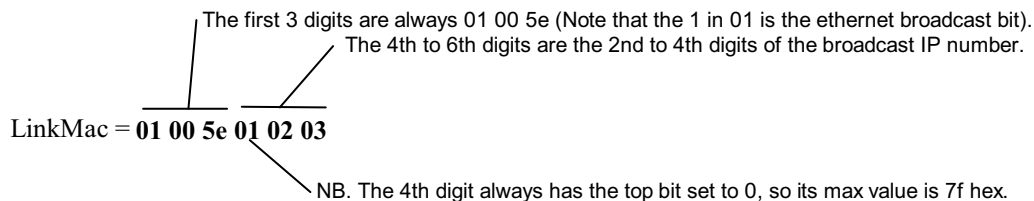

3. Save-button = Save the settings above. This sets up the link and commits it to flash memory.

On the receiving units -

1. Using your SNMP workstation enter the IP broadcast group number 224.1.2.3 into the OID IGMPip1 or 2, depending on which serial port you wish to receive the broadcasts.
2. Save-button = Save the settings above.

Notes: - the destination ports on the receiving units must not themselves have links set.  
- Valid IP numbers for IP multicast groups are in the range 224.0.0.0 to 239.255.255.255.

Hardware options -

- The expansion relay I/O option.

This option is provided in a 19" rack mount case approximately twice as wide as the standard unit. The extra inputs and outputs are mounted in the RHS of the unit (as viewed from the front) and feature indicator leds and lamp test button on the front panel and twøpart connectors on the back panel.

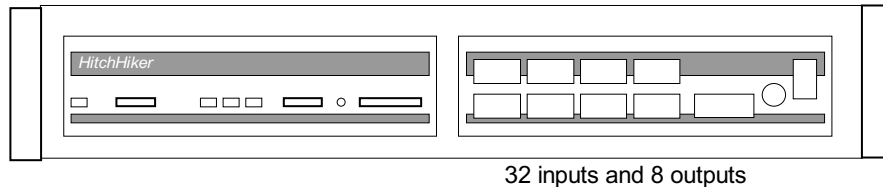

This option provides -

1. Up to 32 contact sense inputs suitable for connection of a volt free switch or relay contact.
2. Up to 8 miniature relays, each presenting a normally closed, normally open and common contact.
3. An indicator panel that shows the states of the contact sense inputs and the relay outputs. This panel has 32 LEDs that indicate the states of the 32 contact sense inputs. Associated with the LEDs are 32 dip switches which allow the user to select whether an led is ON for a closed or open contact. The panel also has 8 LEDs which indicate the current state of the 8 relays. ON means that the common and normally open contacts are connected. In addition, there is a lamp test push button and an ON/OFF power switch.
4. Supported by the optional SNMP software module.

Pin out of the rear panel connectors for the expansion relay I/O option (48Vdc power option shown).

There are three rows of (5.08mm pitch) two part screw connector sockets on the rear panel to terminate the 32 contact inputs and (up to) eight relay outputs. There is also a (3mm pitch) two part screw connector used to terminate -48Vdc power to the unit. The bottom row of connectors carries contact inputs 1 - 16, the middle row carries contact inputs 17- 32, and the top row carries the relay contacts.

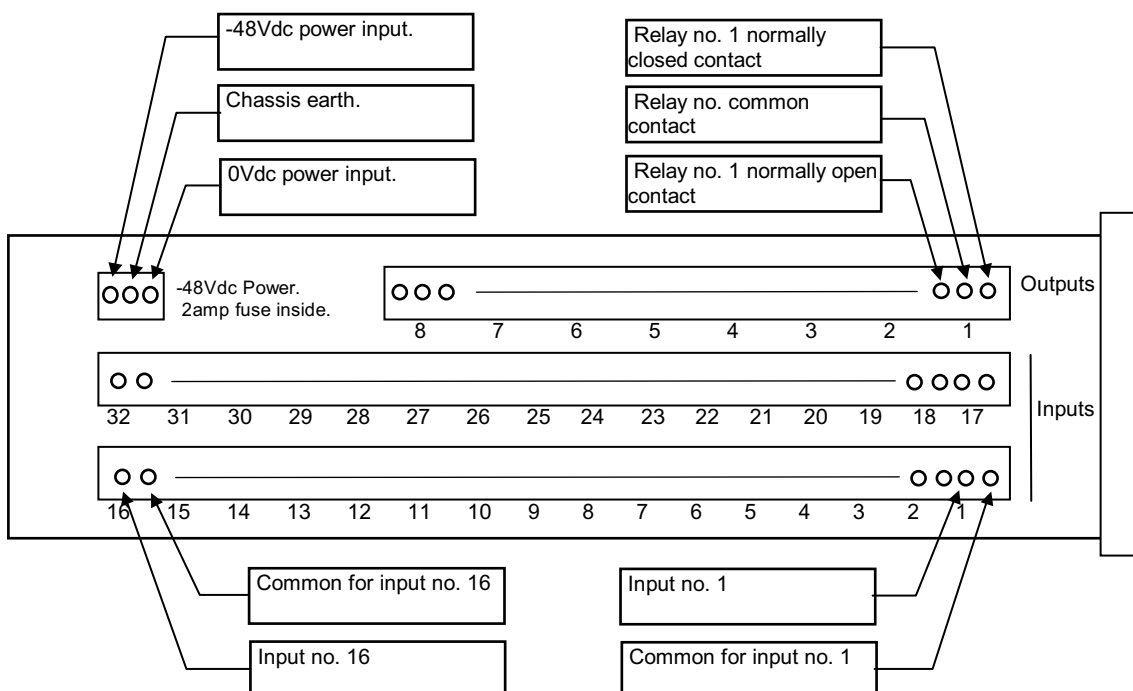

As shown, the inputs are arranged as a pair of pins for each contact input, one pin being signal ground and the other being the contact input as shown above. Note that the contact inputs number from right to left. The outputs are arranged as three pins per relay - normally closed, common and normally open contacts from right to left for a total of 24 pins.

Example usage of the relay expansion option.

An example of how to drive the contact sense inputs pins from a 'voltage free dry contact' e.g. a switch or relay contact, is shown below-

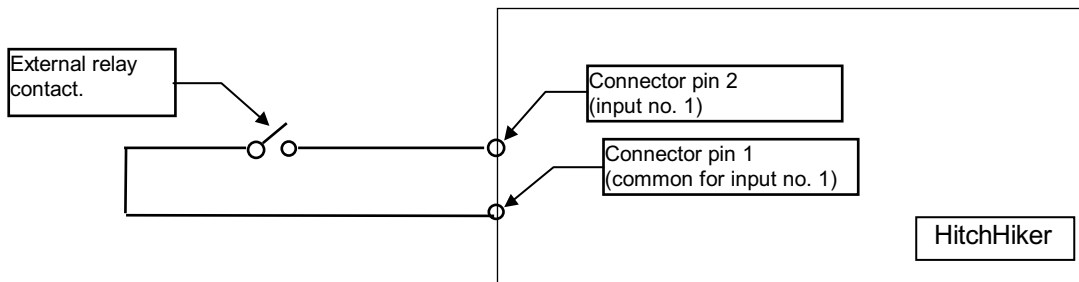

An example of how to use the relay output contacts to drive a TTL gate input-

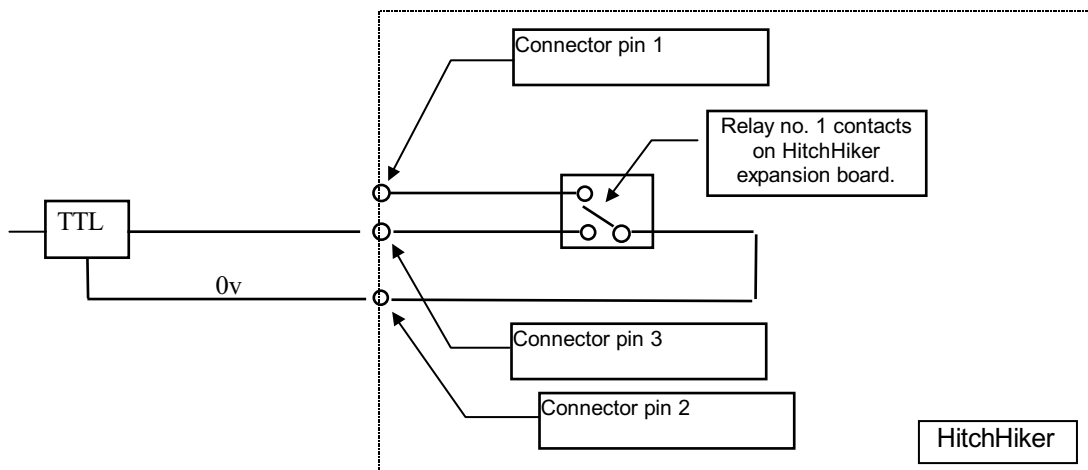

- -48Vdc power supply option.

The expanded I/O HitchHiker can be ordered for use on a -48Vdc battery supply. The internal arrangement of the power supply circuitry is shown below-

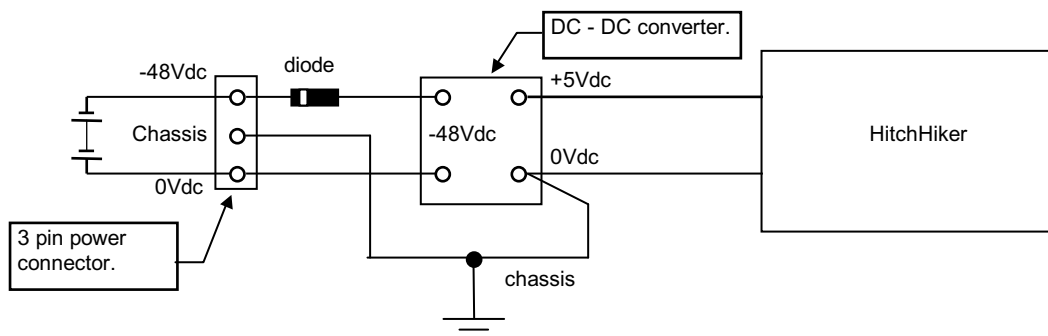

### The Remote Controlled Mains socket.

This unit can be used to control mains power to another equipment, either controlled remotely by HitchHiker, or locally by using the front panel power switch. It is ideal for situations when a host system is available, but located some distance away from the load requiring power control.

It provides the following features:

- **Internal Power Switch** - Allows total control over the state of the socket (on/off/remote control).
- **High Power** - Maximum load may be up to 10 Amps.
- **Standard IEC plug and socket** - Detachable power cords.

When used with the HitchHiker it can be used to control the power to remote equipment.

1<sup>st</sup> method - using digital port to port links -

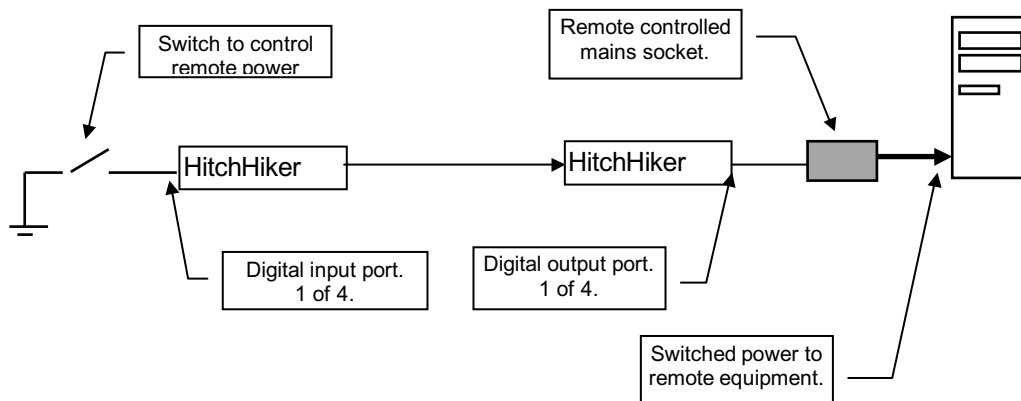

2<sup>nd</sup> method - using the HitchHiker menu system -

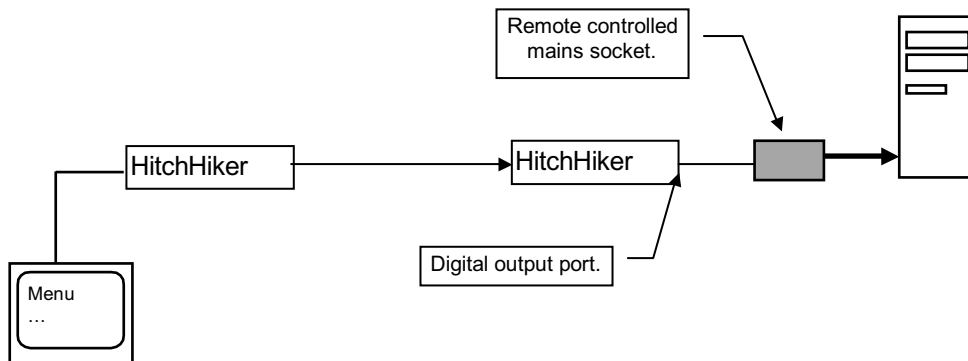

3<sup>rd</sup> method using SNMP -

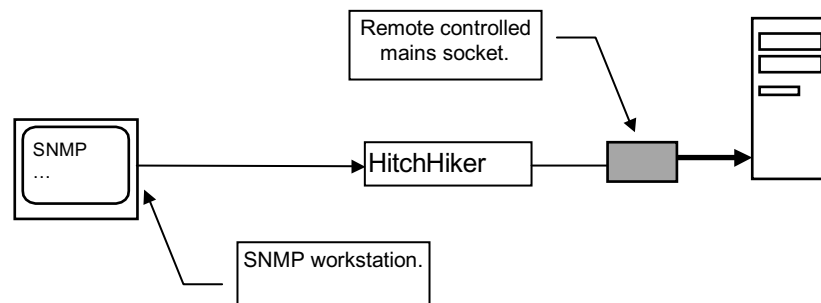

Specifications.

Ratings. 240 VAC 10 Amp 50/ 60Hz  
Relay Coil: 12VDC 70mA 180 ohm  
Size: 3.35”W x 1.9” H x 5.55” D (w/o power cord)

Before using the power module

**Please note the following important considerations for operation of the unit:**

- Do not exceed the Maximum Recommended Ambient of 40 degrees centigrade. Verify that the worst-case temperatures will not exceed this limit.
- Do not exceed the output load limit of 10 Amps.
- Consideration should be given to the connection of equipment to the supply circuit and the effect that overloading of circuits could have on over current protection and supply wiring. Appropriate consideration of equipment nameplate ratings should be used when addressing this concern.
- Ensure that the operation environment has humidity of less than 90% non-condensing.

Front Panel

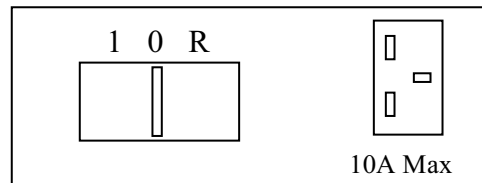

Power Switch

The power switch controls the power out of the unit and may be positioned in one of three positions: (0) centre is off, (1) left is on and (R) right is remote control.

Receptacle

The receptacle is for load connection. **Ensure that the total output Load does not exceed 10 Amps.**

Rear Panel

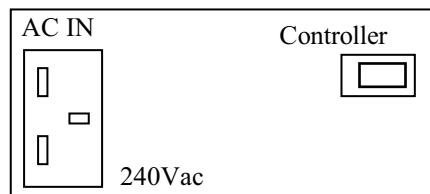

AC Input socket.

The unit has a single IEC input power connector. A standard mains power cable is plugged into this socket.

Controller socket.

Connect the controller cable to this RJ11 connector. This port allows the receptacle to be turned off and on by HitchHiker. The other end of this cable should connect to the HitchHiker on its Digital output port.

Installation.

**Warning: No User Serviceable Parts Inside. Opening the unit will void the manufacturer warranty and could subject the operator to lethal voltages! Return the unit to your reseller for repair if necessary.**

- 1) Attach the load to the receptacle on the front of the unit. This may be a printer, CPU or any device with the proper power connector and rated at 10 Amps or less.
- 2) Connect the controller cable between the unit controller port and the HitchHiker Digital output port, choosing one of the four provided digital outputs.
- 3) Making sure the Power Switch, on the front panel, is in the centre (0) / off position, plug in mains power to the IEC socket marked AC IN.

Manual Operation.

Push the power switch to the left (L). The load connected to the receptacle should turn on.

HitchHiker Operation.

Push the power switch to the right (R). Using HitchHiker, activate the chosen digital output - this can be done either by 1) using the menu system, or 2) using the SNMP option, or 3) by making a HitchHiker digital port link, which links another units digital inputs to this units digital. The load connected to the receptacle should turn on.

Control Port Pin Outs.

The control port is an RJ11 connector wired as shown -

Pin	Function
1	Return
2	Return
3	V+ (12VDC nominal)
4	V+ (12VDC nominal)

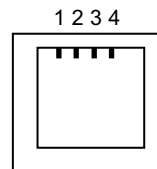

Connecting to a HitchHiker.

The pin outs of the two part screw connector for the digital output port are (as viewed from the rear) -

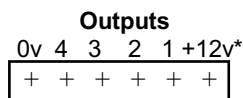

\* NB - must be set to +12v by internal link.

So it is necessary to connect this connector to a remote controlled socket using wiring as shown -

HitchHiker digital output port 1	1 <sup>st</sup> Remote controlled socket RJ11 pin
+12v	3 & 4
Output 1	1 & 2

To connect a 2<sup>nd</sup>, 3<sup>rd</sup> and 4<sup>th</sup> remote controlled sockets, wire as above but connect to HitchHiker outputs 2,3 and 4, as shown -

<u>HitchHiker digital output port 2</u>	<u>2<sup>nd</sup> Remote controlled socket RJ11 pin</u>
+12v	3 & 4
Output 2	1 & 2
<u>HitchHiker digital output port 3</u>	<u>3<sup>rd</sup> Remote controlled socket RJ11 pin</u>
+12v	3 & 4
Output 3	1 & 2
<u>HitchHiker digital output port 4</u>	<u>4<sup>th</sup> Remote controlled socket RJ11 pin</u>
+12v	3 & 4
Output 4	1 & 2

Trouble shooting.

First, always make sure that the mains socket that the unit is plugged into works with another device.

Problem: Load will not turn on.

Solution: Make sure power cord is plugged into the unit and the wall

Problem: Load will not turn on when switch is in “R” mode.

Solutions:

Make sure that the controller cable is plugged into the unit and the HitchHiker.

Ensure that link LK7 situated just behind the digital output port, is set the 12V position.

Check the pin outs shown above.

Problem: Load will not turn off when switch Is In “R” mode.

Solution:

The host hardware is not turning off. Try disconnecting the controller cable. If the load turns off, the problem is with the host hardware.

## Addendum 2.

### HitchHiker protocol.

HitchHiker supports members of the TCP/IP suit of protocols, namely IP, ARP, ICMP, SNMP and UDP. It will also respond to a Ping (ICMP). HitchHiker's uses UDP transport exclusively, and its own protocol and the transported data is carried inside UDP datagrams. The data carried is 1 byte minimum (after time out) and 256 bytes maximum. The Ethernet encapsulation is as defined in RFC 894 and mandated by RFC 1022. The packet format is shown below -

#### Mac Header -

- 6 bytes Destination MAC address
- 6 bytes Source MAC address
- 2 bytes Type - 0800 for IP packets, 0805 for ARP requests and 0806 for ARP replies.

#### IP header -

- 2 bytes IP Version - 4, header length - 20, TOS - 16 (4510h)
- 2 bytes IP packet length including header
- 2 bytes identifier (packet number, unique over a short period)
- 2 bytes fragmentation - 00
- 2 bytes TTL - 64, protocol - 17= UDP (4011h)
- 2 bytes header checksum
- 4 bytes Source IP number
- 4 bytes Destination IP number

The UDP fields contain either - 1) Normal HitchHiker mode

#### UDP header -

- 2 bytes Source port - 8500 (2134h)
- 2 bytes Destination port - 8500 (2134h)
- 2 bytes length of UDP portion including header
- 2 bytes optional UDP checksum - set to 00.

#### HitchHiker header -

- 2 bytes spare
- 2 bytes byte 1 - 34h or 0b4h, byte 2 - 32h. HitchHiker ID code.
- 1 byte Command(1)= 0000cccc where cccc is decoded as -
  - 01 - ACK
  - 02 - Start link
  - 03 - Multicast - who is there?
  - 04 - Multicast reply
  - 05 - Command packet
    - Sequence # bits re-used as -
    - 01 - enquiry; send configuration
    - 02 - reply to enquiry
    - 03 - new configuration data to be adopted
    - 07 - heartbeat (unicast to own Mac)
  - 08 - Data packet
- 1 byte Command(2)= ddss0nnn -
  - where dd= destination port # and ss= source port #, range 0 - 2,
  - and where nnn= packet sequence number; range 0 - 7.

#### HitchHiker data -

- 1- 256 bytes - May be user data or protocol data, as defined above.

Or 2) if 'raw UDP packets' are chosen -

#### UDP header -

- 2 bytes Source port - 6000 (serial port 1) or 6001 (serial port 2)
- 2 bytes Destination port - user selected
- 2 bytes length of UDP portion including header
- 2 bytes optional UDP checksum - set to 00.

#### UDP data -

0- 256 bytes - user data.

### Addendum 3.

#### HitchHiker menu tree.

##### Section 1...

To enter the HitchHiker menu - 1) Press the front panel push button, or 2) Type ++++ into port 2, or if an arming string has been set, send {AS}N to port 2, where {AS} represents your chosen arming string.

#### HITCHHIKER - ROOT MENU

- 1 - Set up Link
- 2 - Configure Unit
- 3 - Display units on line
- 4 - Print units on line
- 5 - Display statistics
- S - Save settings
- ESC Quit without save

##### 1. Set up Link

- Enter name of Source Unit - Name - HITCHHIKER
- Enter Password for Unit - Password - \*\*\*\* (default pass)
- Enter source Port number - 2 (choose 1,2,3 or 4)
- Enter name of Destination Unit - Name - (enter name, IP no. or 'None' to remove link, or 'Multi' to broadcast, or 'UDP IPno UDPsktno' to send raw UDP packets) - Checking units on line
- Select Destination Port of Link - 1 (choose 1,2,3,4.)
- Select Time-out for Destination Port of Link - 2 (choose 50ms, 2 sec, 20 sec, 2 min or never.)
- S - Save settings
- ESC Quit without save

##### 2. CONFIGURE UNIT HITCHHIKER. Go to section 2 for sub menus ————— Section 2

- 1 - Configure serial port 1 - named port1
- 2 - Configure serial port 2 - named port2
- 3 - Configure parallel port - named port3
- 4 - Configure Digital I/O port - not linked
- 5 - Rename Unit
- 6 - Change Password
- 7 - Change IP numbers
- 8 - Change when to send packet parameters
- 9 - Reset to Factory Defaults
- A - Change arming string
- S - Save settings
- P - Return to previous menu
- ESC - ROOT MENU

##### 3. List of all units on line

LOCAL Unit name — HITCHHIKER MAC 00201D000428 IP 0.0.0.0 V1.31  
Port name — port1 is a destination port  
Port name — port2 is a destination port  
Port name — port3 is a destination port  
Port name — port4 is a destination port  
Press space to continue when list is complete

Unit Name      Ser1 name   Ser2 name   Par name   MAC number   Version

- |  |     |       |       |       |              |      |
|--|-----|-------|-------|-------|--------------|------|
|  | BOB | port1 | port2 | port3 | 00201D000439 | 1.31 |
|  | 386 | port1 | port2 | port3 | 0040332D9B2B | 2.00 |
4. As above, sent to the parallel output port.

5. HITCHHIKER Statistics -

Shows total Packets sent and received, and by packet type - data, ack, link, multi, info, query, reply and config.

Section 2...

From section 1 ——— Configure Unit sub menus.

- 1 - Configure serial port 1 - named port1
- 2 - Configure serial port 2 - named port2
- 3 - Configure parallel port - named port3
- 4 - Configure Digital I/O port - not linked
- 5 - Rename Unit
- 6 - Change Password
- 7 - Change IP numbers
- 8 - Change when to send packet parameters
- 9 - Reset to Factory Defaults
- A - Change arming string
- S - Save settings ——— return here to save ———@
- P - Return to previous menu
- ESC - ROOT MENU

1. and 2. PORT HARDWARE CONFIGURE

Port named port1/2 is set-up for Xon/Xoff controlled input

9600 Baud No Parity 1 Stop bits and 8 Data bits

- 1 - Baud
- 2 - Stop
- 3 - Parity
- 4 - Data bits ——— Selections 1 to 7 sub menus in section 3 ———
- 5 - Handshake
- 6 - Rename Port
- 7 - 8 channel receiver
- 8 - Output delays
- S - Save settings, P - Previous Menu, ESC Root Menu

3. PARALLEL PORT CONFIGURATION

Parallel port named port3 is configured for Centronics Input

- 1 - Set as CENTRONICS OUTPUT
- 2 - Set as CENTRONICS INPUT
- 3 - Set as DATA PRODUCTS INPUT
- 4 - Set as DATA PRODUCTS OUTPUT
- 5 - Rename port
- S - Save settings, P - Previous Menu, ESC Root Menu

4. Configure Digital I/O port -

	Pin1	Pin2	Pin3	Pin4
Last recorded state of input lines	HIGH	HIGH	HIGH	HIGH
Last recorded state of output pins	LOW	LOW	LOW	LOW

- 1 - Set output pin 1
- 2 - Set output pin 2
- 3 - Set output pin 3
- 4 - Set output pin 4
- U - Update unit - save changes and re-read inputs
- P - Previous Menu, ESC Root Menu

5. Enter new unit name - ? \_\_\_\_\_ return to @ to save
6. Enter new pass word for unit HITCHHIKER  
New password - ? \_\_\_\_\_ return to @ to save
7. Change IP numbers  
The units IP number is 0.0.0.0  
The default gateway IP number is 0.0.0.0  
The sub-net mask is 0.0.0.0  
1 - Change IP number  
2 - Change Router IP number  
3 - Change Local Net Mask \_\_\_\_\_ return to @ to save
8. Change when to send a packet parameters  
Current time-out is 10  
Current maximum packet size is 256  
1- Change time out from last packet sent - 1 - 127ms. 0=feature off  
1 - Change time-out from last character received - 10msec units 1-127. 0=feature off  
2 - Change Size of pkt to send - Max packet size (1-256) - ?  
S - Save settings, P - Previous Menu
9. RESET TO FACTORY DEFAULTS  
1 - Confirm reset unit HITCHHIKER to Factory defaults(inc. password)  
P - Previous Menu, ESC Root Menu \_\_\_\_\_return to @ to save

#### A. Change Arming string

- Current string is - none
- 1 - Change string
  - S- Save settings, P - Previous menu, ESC Root Menu.

#### Section 3...

From section 2 \_\_\_\_\_ 1 - Configure serial ports 1 and 2, sub-menus -

- 1 - Baud
- 2 - Stop
- 3 - Parity
- 4 - Data bits
- 5 - Handshake
- 6 - Rename Port
- 7 - 8 channel receiver
- 8 - Output delays

#### 1. SELECT BAUD RATE

- 0 - 38k4
- 1 - 19k2
- 2 - 9600
- 3 - 4800
- 4 - 2400
- 5 - 1200
- 6 - 600
- 7 - 300
- 8 - 150
- 9 - 110

#### 2. SELECT STOP BITS

- 1 - 1 stop bit

2 - 2 stop bits

3. SELECT PARITY

- 1 - NONE
- 2 - 0 Parity
- 3 - ODD
- 4 - EVEN

4. SELECT DATABITS

- 1 - 7 bits
- 2 - 8 bits

5. SELECT HANDSHAKE

- 1 - Hardware
- 2 - Input generating Xon/Xoff
- 3 - Output responding to Xon/Xoff
- 4 - Bi-directional Xon/Xoff
- 4 - DTR/DSR direct end to end (plus one of above)
- 5 - Turn off end to end direct

6. Current name is port1

New Name - David

7. Port named port2 is set-up for Xon/Xoff controlled input

8 port receiver mode ON.  
9600 Baud No Parity 1 Stop bits and 8 Data bits

8. Change output delays

Current character delay is 0msec

1. Change character delay

S- Save settings, P - Previous menu, ESC Root Menu.